



BB-LFP-100Ah-P

User's Manual

Product Version: V1.00

1. Introduction

Table of Contents

1. Introduction	2
1.1 Product Description	2
1.2 Scope of Supply	3
2. Safety Instructions	5
2.1 Safety Identifications	5
2.2 Label Descriptions	5
2.3 Operation Instructions	6
3. Operation Interface	7
3.1 Indicating Lamps	7
3.2 Keys and Interface	10
4. Product Installation	12
4.1 Selection of the Installation Location	12
4.2 Preparations for the Installation of the Product	12
4.3 Installation Instructions of the Product	13
5. Precautions for Installation and Use of the Product	18
5.1 Internal Connection of the Product	18
5.2 Moisture and Water Resistance	18
5.3 Heat Insulation from the Environment	19
5.4 Anti-vibration and Anti-collision	19
5.5 Electric Shock Protection	19
5.6 Attentions	19
5.7 Insulation Protection	20
5.8 Accident Handling	21
5.9 Safety Warnings	22
5.10 Maintenance	22
5.11 Matters Needing Attention	22
6. General Operation	24
7. Battery Management System (BMS) Functions	26
7.1 BMS Functions	26
7.2 Communication Interfaces of BMS	27
8. Product Commissioning	29
8.1 Commissioning Preparations	29
8.2 Commissioning of Functions	29
9. Fault and Maintenance	30
10. Specification Table of the Product	32
11. Diagram of the battery system	33
12. Transportation	34
12.1 Transportation	34
12.2 Inspections after Arrival of the Product	34
13. After-sales Service	35
Warning	37

1. Introduction

1.1 Product Description

The BB-LFP-100Ah-P product (hereinafter referred to as the "Product") is designed for residential photovoltaic energy storage systems. The advanced lithium iron phosphate (LFP) batteries are used for the product, which can be matched with external hybrid inverter, software management system and photovoltaic module system to establish the small smart energy storage system, so as to guarantee the power supply and optimize the power consumption structure of users.

The BB-LFP-100Ah-P product can operate with 1 to 16 battery modules combined in any configuration.

Figure 1.1 External View of the Product (Take 1-4 packs of batteries as an example)



1. Introduction

Figure 1.2 Equipment Components

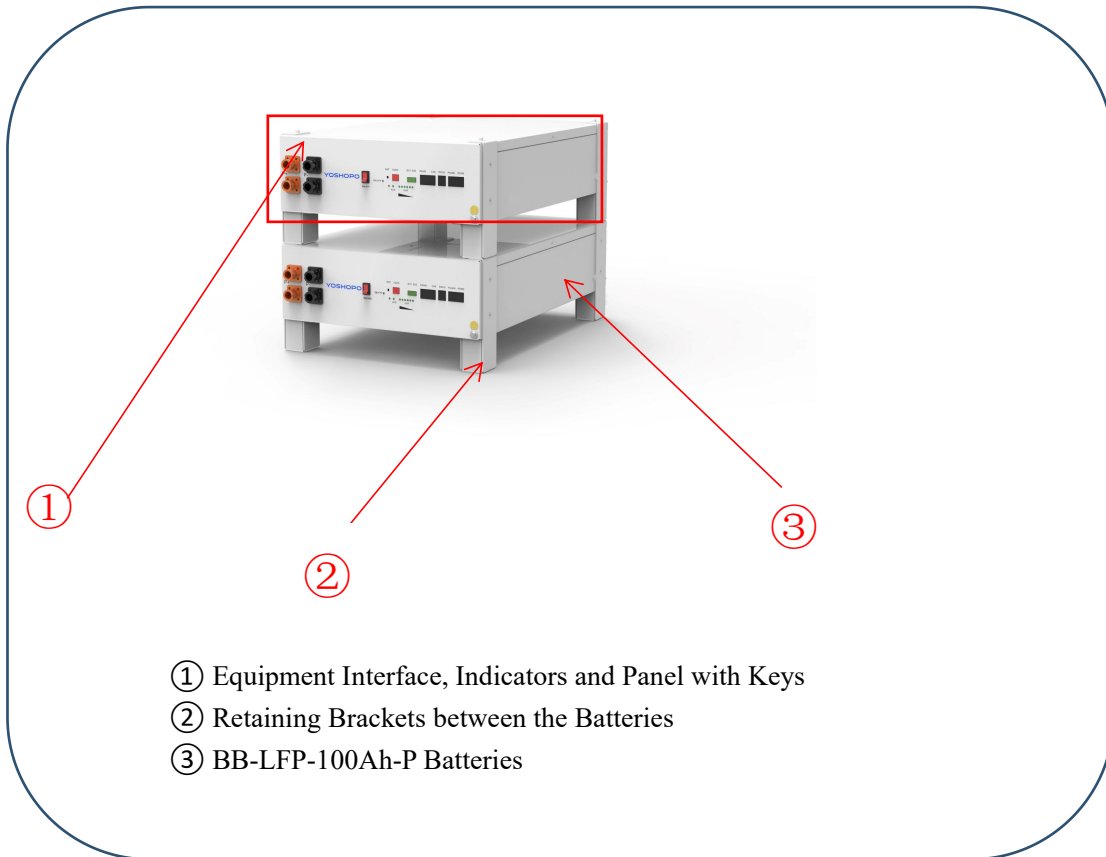

1.2 Scope of Supply

BB-LFP-100Ah-P is composed of the battery cabinet and the following parts. Please check whether the parts are complete when you receive the product:

Table 1.1 Scope of Supply

Serial No.	Product Name	Specification	Quantity	Unit	Remarks
1	Lithium iron phosphate (LFP) battery cabinet	BB-LFP-100Ah-P, 100Ah, 51.2V;	N	Set	White/gray color may be selected as required by Party A
2	Part-Parallel wiring harness assembly of the battery cabinet	Positive power line *1; Negative power line *1; Parallel communication line *2; Grounding line * 1	N-n	Set	1. Total number of battery cabinet/boxes-quantity composing the battery system 2. The power line connector is a quick-connect plug that requires no special tools for installation and

1. Introduction

					connection. With a protection rating of IPXXB, it prevents finger contact with live terminal parts.
3	Part- Retaining bracket assembly of the battery cabinet	Stacking and lowering brackets *4; Cross-recessed countersunk head bolts (M5 x 10) *8	N	Set	White/gray color may be selected (Either color may be selected for this part)
4	Part- Lug assembly of the battery cabinet	Lug *2 for the bracket; Cross-recessed countersunk head bolts (M5 x 10) *4	N	Set	
5	Part- External wiring harness assembly for battery cabinet	Positive power line *1; Negative power line *1; External communication line *1	n	Set	According to the system quantity required by Party A
6	User's Manual	User's Manual*1	N	Pcs	The quantity should be the same as that of the battery cabinet





Please note that you should check whether the parts are complete after receiving the product. In case of any missing, please contact us immediately for solutions. Improper use of the product may result in the risk of electric shock or burns. You should strictly follow the instructions specified in this Manual during installation and maintenance of the product. Please read this Manual carefully before use and keep it properly for future reference.

2. Safety Instructions

2. Safety Instructions

2.1 Safety Identifications

Safety identifications are used to highlight the potential safety risks and important safety information. The safety identifications used in this Manual are as follows:

	Danger: "Danger" indicates a hazardous condition which, if not avoided, will result in death(s) or serious injury/injuries.
	Warning: "Warning" indicates a hazardous condition which, if not avoided, will result in death(s) or serious injury/injuries.
	Warning: "Caution" indicates a hazardous condition which, if not avoided, will result in mild or moderate injuries.
	Attention: "Attention" provides valuable hints on the optimal operation of the product.







2.2 Label Descriptions

Nameplate of BB-LFP-100Ah-P

Rechargeable Li-ion Battery System	
Product Model Name: BB-LFP-100Ah-P	
Battery System Designation: IFpP/51/161/120/[16S]M/-20+50/90	
Nominal Voltage: 51.2Vd.c.	Rated Capacity: 100Ah
Short Circuit Current: 2000A	Weight: 45kg
Duration at Short Circuit Current: 600 μ S	IP Code: IP22
Size: 387(W) \times 581(D) \times 133(H)mm	
Contemporary Nebula Technology Energy Co.,Ltd.	
Add: No. 26-1, Majiang Road, Mawei District, 350000 Fuzhou City, Fujian Province, PEOPLE'S REPUBLIC OF CHINA	
Tel: +86-0591-83970008	

2. Safety Instructions

Warning Labels

Icon	Name	Implication
	Wear Protective Glasses	To remind the operator of wearing protective glasses during installation, maintenance and disassembly
	Refer to User's Manual	To remind the operator of referring to the inserted User's Manual of the energy storage product.
	Beware of Explosion	To remind the operator of keeping away from inflammable and explosive places or areas when installing the product.
	Recyclable	To remind the operator of recycling the scrapped product through a special recycling channel
	Caution	To remind the operator of paying attention to the safety utilization of electricity during the use of the product
	Battery Recycling	To remind the operator of consulting the local environmental protection authority for resource recovery at the local disposal site when the battery is scrapped
	No littering	Waste batteries are forbidden to be discarded randomly. Operators need to seek legal and compliant disposal from relevant qualified authority.

2.3 Operation Instructions

BB-LFP-100Ah-P is designed and produced in accordance with relevant safety regulations; and the needs of end users have carefully been considered. Therefore, the following requirements should be followed during the installation and use of the product:

- The retaining between battery cabinets should be secure;
- The product should be installed in an external system with good grounding;
- Electrical installation shall comply with all the applicable regulations and standards;
- Installation of the product should be carried out as specified in the Manual;
- Installation of the product should be carried out according to proper technical specifications;
- It shall be ensured that the installation personnel have received strict training on electrical installation and obtained relevant work permits for special operations;
- The product needs to be charged once every 3 months, which should be charged to 40% SOC under the standard charging condition and stored at 25±2°C.

3. Operation Interface

3. Operation Interface

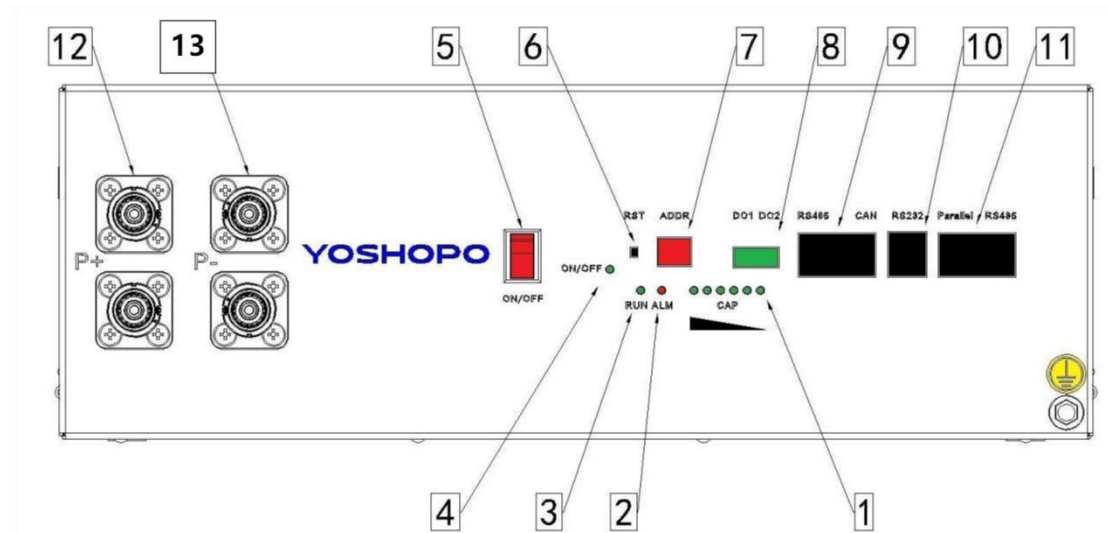

The operation interface of BB-LFP-100Ah-P is shown in the Figure above;

The BB-LFP-100Ah-P product uses indicator lights and buttons to display the product's status, operational information, and settings.

3.1 Indicating Lamps

Table 3.1 Indicating Lamps

Serial No.	Name	Description
1	Capacity Indicating Lamps	CAP Indicating Lamps; There are six battery capacity indicating lamps, each of which indicates 16.6% of the battery capacity.
2	Alarm Indicating Lamp	ALM Indicating Lamp, red in color; The indicating lamp of product will be on when there is a fault.
3	Running Indicating Lamp	RUN Indicating Lamp, green in color; The indicating lamp will be always on when charging and flash when discharging.
4	State Indicating Lamp	ON/OFF Indicating Lamp, green in color; The indicating lamp will be always on when the ON/OFF Key is turned on.

3. Operation Interface

Table 3.2 Information of Capacity (CAP) Indicating Lamps

State		Charging						Discharging					
Capacity indicating lamp		L6	L5	L4	L3	L2	L1	L6	L5	L4	L3	L2	L1
		●	●	●	●	●	●	●	●	●	●	●	●
Electric quantity (%)	0~16.6%	Off	Off	Off	Off	Off	Flash 2	Off	Off	Off	Off	Off	Always on
	16.6~33.2%	Off	Off	Off	Off	Flash 2	Always on	Off	Off	Off	Off	Always on	Always on
	33.2~49.8%	Off	Off	Off	Flash 2	Always on	Always on	Off	Off	Off	Always on	Always on	Always on
	49.8~66.4%	Off	Off	Flash 2	Always on	Always on	Always on	Off	Off	Always on	Always on	Always on	Always on
	66.4~83.0%	Off	Flash 2	Always on	Always on	Always on	Always on	Off	Always on	Always on	Always on	Always on	Always on
	83.0~100%	Flash 2	Always on	Always on	Always on	Always on	Always on	Always on	Always on	Always on	Always on	Always on	Always on
Running Indicating Lamp ●		Always on						Flash (Flash 3)					

Table 3.3 Flashing Descriptions of LED

Flashing Mode	On	Off
Flash 1	0.25S	3.75S
Flash 2	0.5S	0.5S
Flash 3	0.5S	1.5S

3. Operation Interface

Table 3.4 Descriptions of Indicating Lamps

State	Normal/ Alarm/ Protection	ON/OFF	RUN	ALM	LED for Electricity Quantity Indication						Description
		●	●	●	●	●	●	●	●		
Shut down	Dormant	Off	Off	Off	Off						All are off
Standby	Normal	Always on	Flash 1	Off	According to electric quantity indicating lamp						Standby state
	Alarm	Always on	Flash 1	Flash 3							Low voltage of module
Charging	Normal	Always on	Always on	Off	According to electric quantity indicating lamp (LED 2 flashes when electricity quantity indicates the maximum level)						When electricity quantity indicates the maximum level, LED (LED 2) flashes. ALM indicating lamp does not flash when an overcharge alarm is made.
	Alarm	Always on	Always on	Flash 3							
	overcharge protection	Always on	Always on	Off	Always on						Due to no mains power, the indicating lamp switches to the standby state
	Over-temperature, over-current and failure protection	Always on	Off	Always on	Off						Stop charging
Discharging	Normal	Always on	Flash 3	Off	According to electric quantity indicating lamp						
	Alarm	Always on	Flash 3	Flash 3							
	Under-voltage protection	Always on	Off	Off	Off						Stop discharging
Discharging	Over-temperature, over-current, short circuit, reverse connection and failure protection	Always on	Off	Always on	Off						Stop discharging
	Failure	Off	Off	Always on	Off						Stop charging and discharging

3. Operation Interface

3.2 Keys and Interface

Table 3.5 Keys and Interface

Serial No.	Name	Description
5	On-Off Key	The product enters the normal running state or the shutdown state
6	Reset Key	RST Key; It can be used to reset the product when an abnormal condition occurs
7	Dip Switch	ADDR switch; It can be used to set the module address
8	Dry contact	DO1 and DO2; Two dry contact outputs are reserved
9	Communication with the upper computer	communication with PCS with RS485 or CAN, with 2 RJ45 interfaces
10	Debugging port	RS232, an interface for debugging
11	Parallel communication interface	Parallel RS485, used to parallel module communication, with 2 RJ45 ports
12	Battery positive electrode	Used to connect the positive electrode of a battery module
13	Battery negative electrode	Used to connect the negative electrode of a battery module

Action Description of the Buzzer

The buzzer buzzes for 0.25s every 1s when a fault occurs, 0.25s every 2s for protection (except for overvoltage protection), and 0.25s every 3s for alarms (except for overvoltage alarms). The buzzer function may be enabled or disabled by the application software of the master computer, which is set as "Disabled" by factory default.

Description of Reset Key (RST)

When the BMS is in the dormant state, press the key (3~6s) and release it. The protection board will be activated, and the LED indicating lamps will turn on for 0.5S from "RUN". When the BMS is in the activated state, press the key (3~6s) and release it, the protection plate will be dormant, and the LED indicating lamp will be on for 0.5S from the indicating lamp with the lowest electric quantity. When the BMS is in the activated state, press the key (6~10s) and release it. The protection plate will be reset and all the LED indicating lamps will be on for 1.5s simultaneously.

After the BMS is reset, the parameters and functions set by the upper computer will still be retained. "Restore Defaults" of the upper computer may be used to restore to the initial parameters if required. However, relevant running records and stored data (such as electric quantity, number of cycles, and protection records) will remain unchanged.

3. Operation Interface

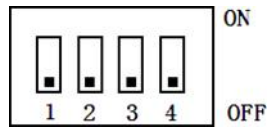

Setting of the Dip Switch

When packs are used in parallel, you may set the addresses of different packs by using the dip switch on the BMS. Avoid setting the addresses to be the same. See the following table for the definition of the dip switch of BMS.

Table 3.6 Address Table of Dip Switch

Address	Position of Dip Switch			
	#1	#2	#3	#4
0	OFF	OFF	OFF	OFF
1	ON	OFF	OFF	OFF
2	OFF	ON	OFF	OFF
3	ON	ON	OFF	OFF
4	OFF	OFF	ON	OFF
5	ON	OFF	ON	OFF
6	OFF	ON	ON	OFF
7	ON	ON	ON	OFF
8	OFF	OFF	OFF	ON
9	ON	OFF	OFF	ON
10	OFF	ON	OFF	ON
11	ON	ON	OFF	ON
12	OFF	OFF	ON	ON
13	ON	OFF	ON	ON
14	OFF	ON	ON	ON
15	ON	ON	ON	ON

4. Product Installation

4. Product Installation

4.1 Selection of the Installation Location

The following factors should be considered when selecting a location to install the product:

- Do not install the product in the airtight confined space. Please ensure the ventilation of the air around the product so as to avoid overheating of the equipment.
- BB-LFP-100Ah-P is designed for indoor application. Do not install it outdoors.
- Avoid the product from direct sunlight and high ambient temperature. Otherwise, the operating temperature of the system will be too high, which will affect the conversion efficiency.
- The battery operating temperature of BB-LFP-100Ah-P ranges from -20 to 55°C; and the optimal operating temperature is 0-25°C. It is recommended that the ambient temperature for installation be within the range of -20°C -45°C.
- The operability of the status indicating lamp and keys should be considered for the installation.
- If installed in an enclosed environment, adequate ventilation shall be provided.
- The product must be at least 3 meters away from any fire source or heat-emitting objects.
- The installation distance between the product and surrounding objects must meet the following requirements: more than 500mm from all four sides of the product, and more than 800mm from the top of the product.



Safety tip: YLB1 system must be installed at the bottom of an isolation tank that does not leak out. If the battery pack leaks electrolyte, please avoid contact with the leaking liquid or gas, and keep away from the device.

4.2 Preparations for the Installation of the Product

Product size:

Table 4.1 Product Size

Cabinet with one pack of battery	Size	387mm(W)*581mm(D)*133mm(H)
	Weight	45Kg (not equipped with the retaining brackets)
	External enclosure thickness and material	1.2mm/DC01

Installation Preparations:

- Please prepare your equipment installation space according to the model purchased.
- Install the product vertically on the ground. Please ensure that the ground is flat and does not tilt.
- There are lithium iron phosphate (LFP) batteries inside the equipment. Be sure to use

4. Product Installation

forklifts or other transport machinery to move the equipment smoothly to the site; avoid bumping or impacting the equipment.

- Remove the outer packing.

4.3 Installation Instructions of the Product

The energy storage system composed of different packs of BB-LFP-100Ah-P lithium iron phosphate (LFP) batteries in parallel should be selected according to the requirements. If the system has only one pack of battery, carry out the installation as specified in Step 1. If the system has two or more packs of batteries, carry out installation following Step 1 and 2.

Step 1:

- (1) Ensure that the ON/OFF Switch of cabinet for each pack of the battery is in “Off” state.

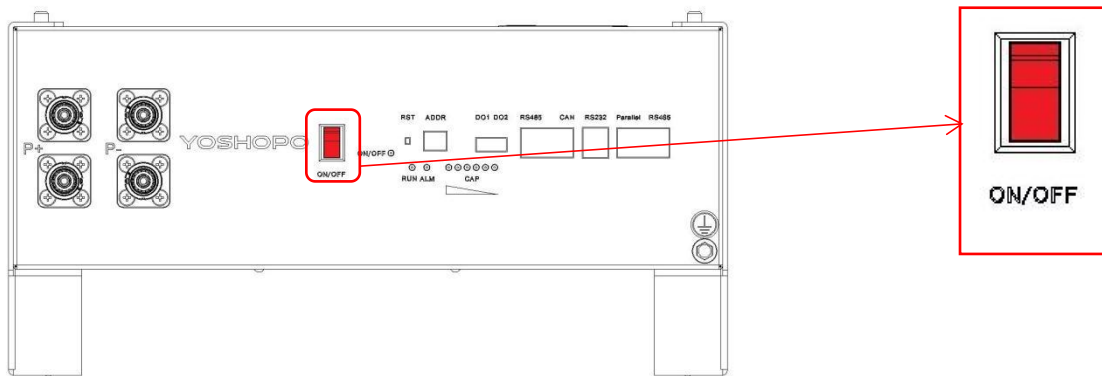

- (2) Use yellow-green PE wiring harness to connect the grounding point of the outer shell of the cabinet for each pack of the battery to the nearby grounding point, the torque is 5 N • m.

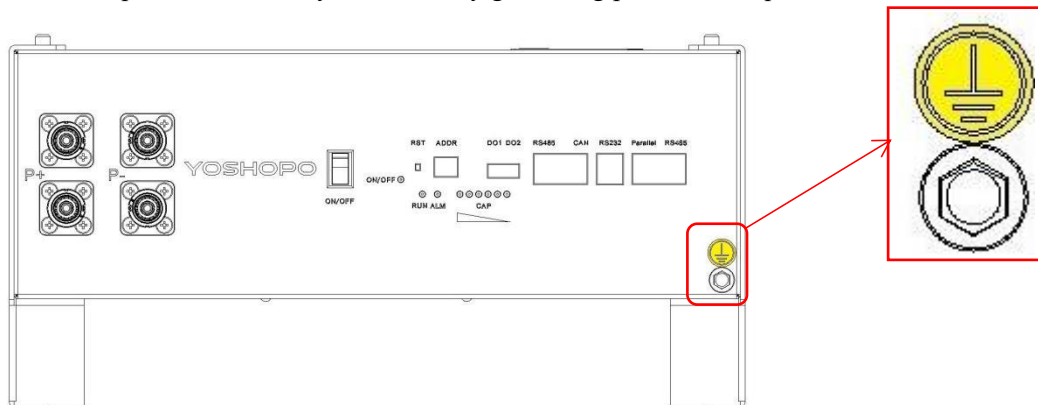

- (3) Connect the positive and negative electrodes of the battery cabinet to the battery of the residential energy storage control system by using the power connection line. The orange ports are the positive electrodes and the black ports are the negative electrodes. In case of multiple battery packs, connect the uppermost battery pack.

4. Product Installation

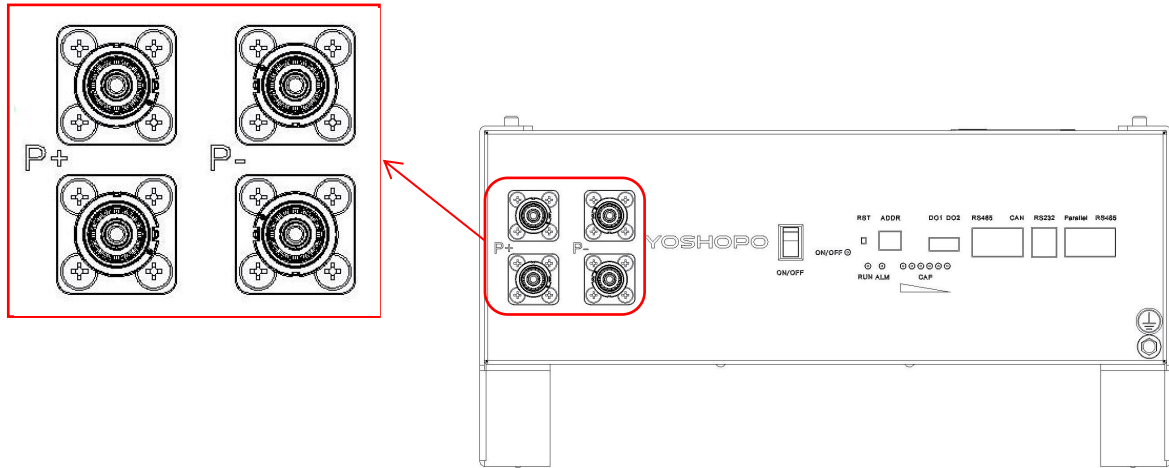

(4) Connect the communication wiring harness of the residential energy storage system to the communication interface on the battery cabinet. In case of multiple packs of batteries, set the Dip Switch of the battery cabinet connected to inverter as 1, and perform the Dip operations for the other battery cabinets successively. Besides, make sure that the Dip addresses of various battery cabinets are different, and then connect the uppermost pack.

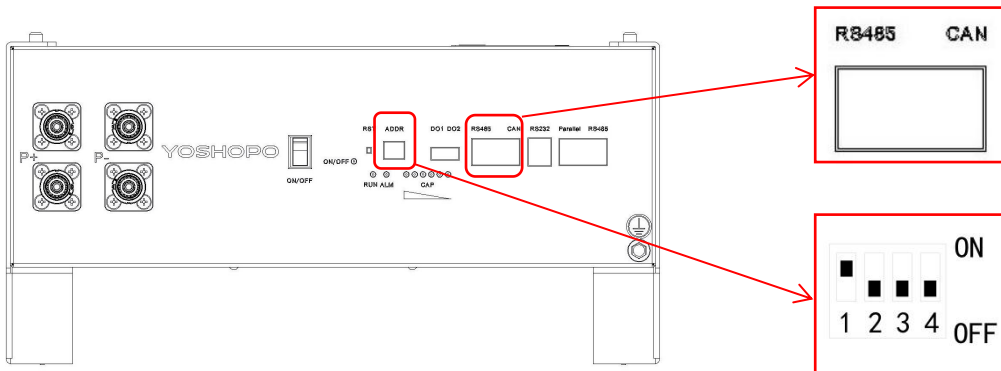

4. Product Installation

Step 2:

(1) Each bracket of every battery pack has a hole and a pin. To connect them, simply insert the pin from the lower battery's bracket into the hole of the corresponding bracket on the upper battery.

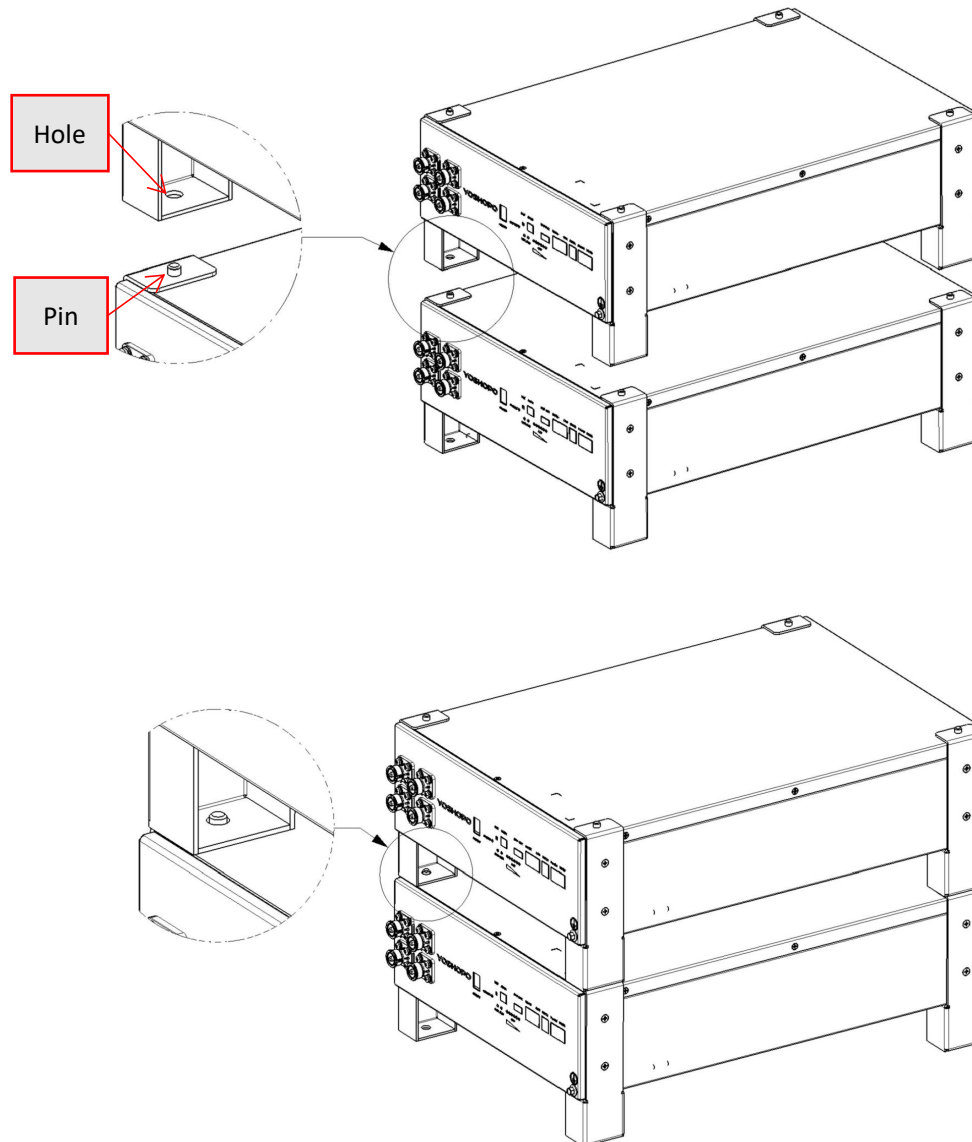

(2) Starting from the second battery pack from the top, use power connection cables to sequentially connect the positive terminal (+) of one battery pack to the positive terminal (+) of the adjacent pack, and the negative terminal (-) to the negative terminal (-), through circuit breakers (Specifications: Rated working current: 63A; Number of poles: 2P; Running short-circuit capacity $I_{cs} = 10\text{kA}$). The positive terminal is orange, and the negative terminal is black. Ensure each connector plug is securely installed by listening for a "click" sound.

4. Product Installation

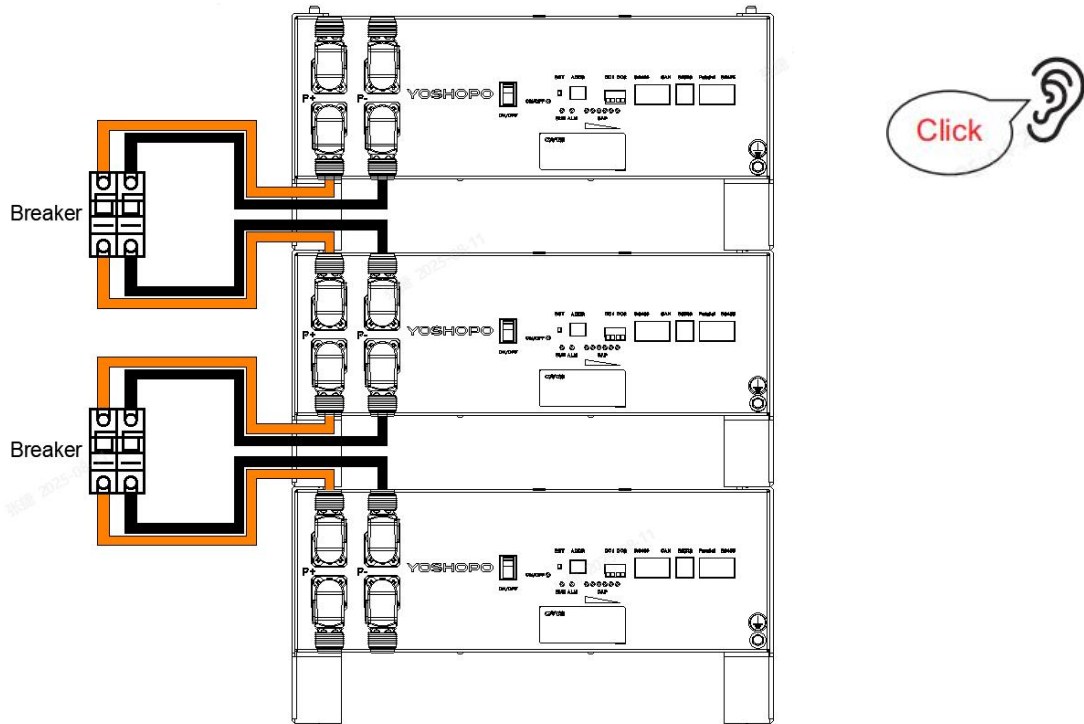

(3) Connect the pack to the inverter by setting its DIP switch to "1" as the master unit. Set the remaining packs in sequence. Use twisted-pair cables with RJ45 plugs on both ends to connect the dual RS485 parallel communication ports of adjacent battery packs. During installation, confirm proper connection when the RJ45 plug emits a "click" sound.

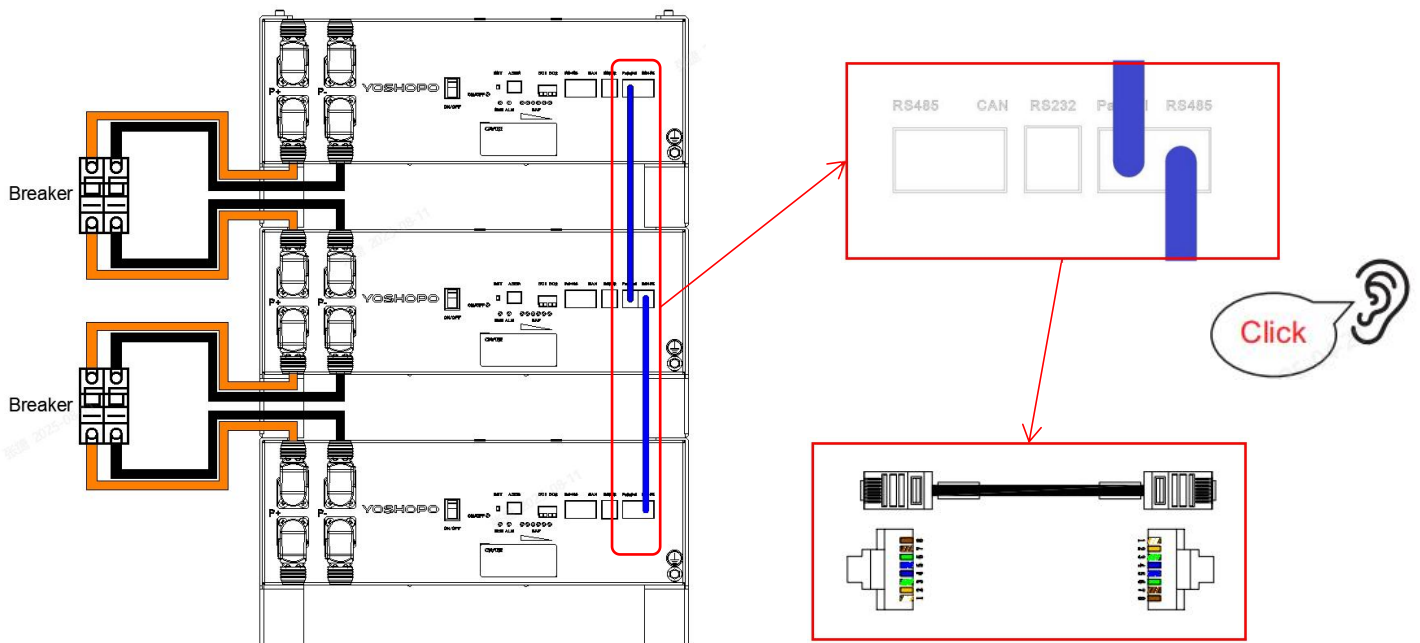

4. Product Installation

(4) After the product is installed, when it is connected to the power line of the external equipment, the circuit breaker shall be installed on the positive and negative power line. The circuit breaker specification is: Rated working current: 125A; Number of poles: 2P; Running short-circuit capability: I_{cs} -10kA.

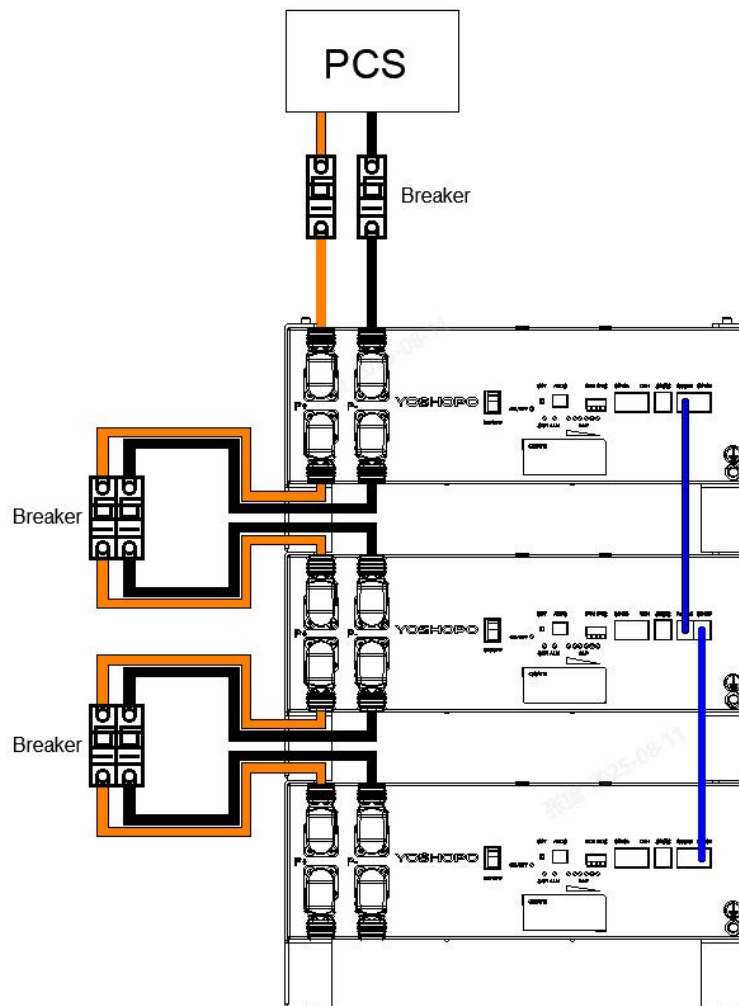

5. Precautions for Battery System Installation and Use

5. Precautions for Installation and Use of the Product

The battery product is the energy storage equipment and classified as hazardous products. Therefore, non-professional installation and improper operation or use may lead to electric shock, combustion, explosion and other serious consequences. The installation and maintenance of the battery product shall be performed by professional technical personnel; and the use of the battery system shall strictly comply with relevant safety regulations. It is prohibited for the non-professional personnel to install, maintain or use the battery product out of prescribed scope.

5.1 Internal Connection of the Product

The following items are involved in the battery product connection:

- (1) All the connectors shall be safe and reliable; it shall be ensured that there are no loosening, virtual contact problems; and connectors should be equipped with corrosion and wear-resistant and anti-seismic functions.
- (2) All the connections shall meet the requirements of relevant national standards; and various forms of arc discharge should be strictly prevented.
- (3) The connections between the internal batteries shall be equipped with anti-seismic and anti-loosening devices; and temperature, voltage and current sensors shall also be connected safely and reliably. Moreover, any metal exposure should strictly be prohibited for all the induction lines.
- (4) Any form of short circuit in the connection process should be strictly avoided.
- (5) It is prohibited for the operating personnel (having not worn protective equipment) to operate by hand.
- (6) All the connections shall be made under clear instructions; and operation of any form of conjecture and vague attempt shall strictly be prohibited.
- (7) The key points of connection: Ensure that the connection is correct, reliable (no loosening) and with good contact (no contact resistance). Besides, there should be no short circuit.
- (8) Measurements and confirmation should be carried out point by point after the connection is completed.
- (9) All the connection points shall be ensured not to contact with the outer box or other parts, and not to cause short circuit.
- (10) It is necessary to consult professionals for confirmation before implementation in case of other uncertain factors.

5.2 Moisture and Water Resistance

The battery product is energy storage equipment with many control lines and unit batteries. Flowing of liquid into the battery product may lead to short circuit, leakage and corrosion of unit batteries, electronic circuits and connectors. Therefore, it shall be ensured that the battery product will not get soaked in various kinds of liquid, and that moist air will not get into the battery product. Furthermore, the battery product shall never be exposed to sunlight or be caught in the

5. Precautions for Battery System Installation and Use

rain; Otherwise, maintenance shall be carried out immediately. The waterproof function shall sufficiently be taken into consideration for the installation space of the battery product.

5.3 Heat Insulation from the Environment

The battery product shall be maintained within the optimal working temperature range so that the battery life can significantly be expanded and the battery safety can be improved. The limitations on temperature should fully meet the various definitions in the specifications. The space where the battery product is installed shall be ventilated and insulated. It is strictly forbidden to directly expose the battery system to sunlight; direct heat transfer from sunlight to the batteries or direct dissipation from the batteries to the outside world in cold winter is directly prohibited.

5.4 Anti-vibration and Anti-collision

Since the battery product is connected in series and equipped with the management system and various induction devices, it shall be firmly and reliably installed and no loosening or shaking is allowed. Flipping or slanting installation is strictly forbidden for the battery system. Meanwhile, the bottom of the battery product shall be equipped with anti-vibration cushion pads to prevent violent vibration of the battery product during use; otherwise, it will affect the reliability of the battery connection. There shall be sufficient anti-collision protection devices at the periphery of installation space of the battery product, so as to ensure that general collisions will not directly damage the battery product and batteries and lead to battery safety accidents (such as direct short circuit, overheating and combustion).

5.5 Electric Shock Protection

The battery product has protective covers on the external terminals (positive and negative) and internal insulation protections such as insulating sheets and insulating pillars. When installing, it is important not to remove the external insulation covers prematurely; they should only be removed when making the electrical connections to prevent accidents. After using the battery product, if it is not in use, the insulation covers should be reinstalled on the positive and negative terminals.

5.6 Attentions

1. Non-professional person should not carry out installation and maintenance without authorization;
2. It is prohibited to immerse the product in water. When temporarily stored for later use, it should be placed under cool and dry environment;
3. It is forbidden to use or store the product next to the high heat and temperature sources;
4. It is prohibited to use scrubbing solution or corrosive liquid to wipe the surface of the product;
5. It is forbidden to directly connect the "+" and "-" electrodes of the product;
6. The product has a sealed structure. It is forbidden to disassemble the product and various components;

5. Precautions for Battery System Installation and Use

7. It is prohibited to knock or throw, trample, collide or strongly vibrate the product;
8. Avoid installation in radiation environment;
9. Avoid installation in areas with corrosive gases and liquids;
10. Please mark the escape routes after installation.
11. The battery product transmits signals to the sound & light alarm and starts the sound & light alarm;
12. When the sound & light alarm starts, please stay away from the site immediately and contact the after-sales service center for help.

Notes: External audible or visual alarms with RS485 communication protocol are allowed to be connected with communication ports of the battery system to obtain high decibel and visual alarm information. The decibel of alarm devices should be within the range of 3dB~110dB. The battery system will trigger the alarm devices to give audible and visual alarms through the RS485 communication command, especially when battery systems are vented, exploded and burned.

5.7 Insulation Protection

Adequate insulation measures should be taken for all the power connection parts within the battery product. It shall be ensured that the positive and negative electrodes of the batteries will not contact the outer box in any case to lead to leakage and short circuit. At any time, it is necessary to absolutely ensure that the positive and negative electrodes of the battery product will not short out directly; otherwise, serious safety and electric shock accidents may be caused.

5. Precautions for Battery System Installation and Use

5.8 Accident Handling

In case of any abnormal condition or accident in the battery product, correct and effective measures should be taken in time, so as to eliminate further damages and the expanded loss:

1. Overheating: when the battery product overheats, the heat dissipation product will automatically dissipate heat to cool the battery product to the optimal working temperature range under normal circumstances. When the battery product cannot be cooled to the target temperature within the specified time or temperature of the battery product is above the upper limit for safe use, the management system will give an alarm; and use of the battery product is required to stop immediately. In this case, use of the battery product should be stopped immediately, and relevant technical personnel should be informed to carry out a comprehensive inspection; and use of the battery product should not be continued until the fault is eliminated.

2. Electric leakage: In case of leakage of the battery product during use, the personnel in the energy storage room shall be evacuated immediately; and relevant technical personnel shall be informed to deal with the problem immediately, and use of the battery product should not be continued until the fault is eliminated. It is prohibited to use the battery product with faults or forcibly to continue to use the battery product.

3. Over-discharge: When the electric quantity of the battery product is used up, the overall voltage is too low or voltage of some batteries are too low, the management system will give an alarm and the use of the battery product is required to stop and charging shall be carried out immediately. In this case, discharging of the battery product should be stopped and charging of the battery product should be carried out. Do not forcibly discharge the battery product at this time. Otherwise, the battery performance will be damaged, or the batteries may be permanently damaged and cannot be used any longer in serious cases.

4. Short circuit: In case of short circuit of the battery product caused by various reasons, the personnel in the energy storage room shall be evacuated immediately; relevant power supply and electrical equipment shall be cut off (if possible); the connection between the battery and the product shall be disconnected immediately; and relevant technical personnel should be informed to maintain and eliminate the fault immediately. Besides, the battery product severely short-circuited cannot be used again, which shall comprehensively be inspected by the manufacturer before decision is made on whether it can be partly maintained and used.

5. Combustion: In case of a combustion accident of the battery product caused by various reasons, the personnel in the energy storage room shall be evacuated immediately. Meanwhile, irrelevant personnel should not be allowed to approach the energy storage room within the safety range (since there may be explosion hazards). Special fire extinguishers should be used by professionals to extinguish the fire. After the fire is put out, the personnel wearing necessary protective equipment should first cut off the power connection line, and fully discharge the battery product (the voltage should fall to zero volt) before the battery product can be removed for further operation analysis.

6. Collision of the battery product: If the battery product suffers from collision, deformation or is punctured by foreign matters due to various reasons, the power cables of the battery product should be disconnected immediately and the professional technical personnel shall be informed to go to the site to handle the condition. If the battery product should be removed, it should fully be

5. Precautions for Battery System Installation and Use

discharged by the personnel wearing necessary protective equipment before removing the battery product.

7. Other Accidents: If the battery product is required to be repaired or removed due to other accidents, the battery circuit should be disconnected first. The battery product should be removed without short-circuiting the battery. Ensure that the battery product will not be damaged by collision, drop, or inversion. In such case, handling should be carried out according to the regulations mentioned above.

5.9 Safety Warnings

<p>Warnings</p> <p>Due to the potential hazards of batteries, proper precautions shall be taken during operation and maintenance!</p> <p>Improper operation of the tests/experiments described in this Specification may result in serious injuries and property damages!</p> <p>Batteries shall be operated with proper tools and protective equipment. Battery maintenance shall be carried out by the personnel with battery expertise and having received relevant safety training.</p> <p>Failure to follow the above warnings may lead to various disasters.</p>

5.10 Maintenance

1. Customers are obligated to make reasonable maintenance plans, such as monthly dust removal and battery performance inspection plans, so as to ensure the normal use of the product. When dusting, ensure proper insulation protection before performing the cleaning. Do not use wet cloths or other conductive tools for dusting.
2. The scrapped products shall immediately be recycled by the designated qualified manufacturers. It is strictly forbidden to discard them carelessly; otherwise, it may lead to safety accidents or seriously pollute the environment.
3. Charging the battery pack to 50%~60% SOC per six months during the long-term storage.

5.11 Matters Needing Attention

 Warnings	
It is better to reduce power when charging and discharging	[Warning]: It is better to reduce power during charging in case of a warning of high total voltage.
	[Warning]: It is better to reduce power during discharging in case of a warning of low total voltage.

5. Precautions for Battery System Installation and Use

	[Warning]: It is better to reduce power during charging in case of a warning of high unit voltage.
	[Warning]: It is better to reduce power during discharging in case of a warning of low unit voltage.
	[Warning]: It is better to reduce power during charging and discharging in case of a warning of the battery temperature above 50°C.
	[Warning]: It is better to reduce power during discharging in case of a warning of the battery temperature below -15°C.
	[Warning]: It is better to reduce power during charging in case of a warning of charging current above 50A. Failure to reduce power may affect the battery life.
	[Warning]: It is better to reduce power during discharging in case of a warning of discharging current above 50A. Failure to reduce power may affect the battery life.
Maintenance is required for batteries	[Warning]: Maintenance is required in case of too large voltage difference. Failure to carry out maintenance may affect the battery life.
Cut off the circuit immediately in case of short circuit	[Warning]: The circuit should be cut off immediately in case of short circuit. Fuse should be replaced in case of being burnt.

6. General Operation

Routine Use

Power on

(1) After the product installation is completed, first close the positive and negative terminal circuit breaker, then turn on the "ON/OFF" rocker switch. Then the product will enter the standby state. The 'ON/OFF' indicating lamp will be on. The product can be used to support one piece of battery pack to work individually or multiple battery packs to work simultaneously. The operation can be carried out just by turning on the 'ON/OFF' rocker switch of the corresponding battery box.

(2) The product will enter the working state when the communication switching power supply is loaded, and the RUN Indicating Lamp will be on, indicating that the product is in charging status.

(3) When the mains supply and photovoltaic systems stop the power input, the product will provide backup power support to external devices without delay. The RUN Indicating Lamp will flash, indicating that the product is in discharging status.

(4) In case multiple pieces of battery packs work in parallel, set the battery pack connected to the communication wiring of the residential inverter as the master pack, and generally set the Dip address of "ADDR" as 1. Set the other batteries as slave packs, and respectively set different Dip addresses of "ADDR" for them. The setting range of addresses is 2~15 (See the function descriptions mentioned above for the dip setting mode of "ADDR").

Power off

(1) If a single device is in operation, set the "ON/OFF" rocker switch to the OFF position. Confirm that the indicator light is off and the battery system enters the shutdown state.

(2) If multiple devices are operating in parallel, for all devices in the order of the DIP switch addresses 1, 2, 3..., set the "ON/OFF" rocker switch to the OFF position. Confirm that the indicator light is off and the battery system enters the shutdown state.

(3) Disconnect the positive - pole circuit breaker first, and then disconnect the negative - pole circuit breaker.

(4) If you need to perform the next operation, please wait for 5 minutes.

Dormancy and Awakening

Dormancy

When any of the following conditions are met, the product will enter the low power consumption mode:

(1) Unit or total over-discharge protection is still not removed within 30s.

(2) After releasing the key having been pressed for 3~6s.

(3) The minimum unit voltage is below the dormancy voltage, and the duration reaches the dormancy delay time (no communication, balance and current shall simultaneously be met).

(4) Standby time is more than 24 hours (no communication, charging and discharging and mains).

(5) Forcibly power off with the software of the upper computer.

Before entering the dormancy mode, ensure that the input terminal is not connected to external voltage. Otherwise, it cannot enter the low-power consumption mode.

6. General Operation

Awakening

When the product is in the low power consumption mode and meets any of the following conditions, the product will exit the low power consumption mode and enter the normal operation mode:

- (1) Connect to the charger. The output voltage of the charger should be above 48V.
- (2) After releasing the key having been pressed for 3~6s.
- (3) RS232 communication is activated.

7. Battery Management System (BMS) Functions

7.1 BMS Functions

Main functions of BMS are as follows:

(1) Charging and Discharging Management

Charging and discharging control management is carried out according to different conditions.

(2) Voltage and Temperature Monitoring and Balance Management

Voltage and temperature of the system and the batteries are monitored; and balance management is carried out according to the imbalanced conditions of the electric quantity of various batteries.

(3) Communication Function

It is equipped with CAN and RS485 communication functions, to support upper computer monitoring and RS485 network establishing.

The primary communication contents with the inverter include:

- Uploading battery module fault/protection/warning status.
- Uploading parameters: SOC/SOH/voltage/current/temperature/capacity/charge request/discharge request.
- Transmitting statuses: Allowed charging/discharging & forced charging.
- Uploading battery firmware/hardware version information.

(4) Safety Protection

Functions including total voltage over-voltage and low-voltage protection, unit battery over-voltage and under-voltage protection, over-current, short circuit, reverse connection and low-high temperature protections are supported.

(5) Calculation of SOC

Calculate and correct accuracy of SOC. BMS can be used to accurately calculate the SOC of battery packs by integrating current and time, and the accuracy of SOC should be no more than 8% at normal temperature.

(6) State Indicating Lamp

Simple and reliable LED indicating lamps are used to indicate battery capacity and the running state. When an alarm or protection state occurs, the built-in alarm buzzer will immediately make an alarm.

(7) Real-time Important Data Recording

It has a real-time clock module and data storage space, which can be used to record important operations and alarm information during the use of the battery product.

(8) Current-limiting Function during Charging

When the charging current is more than the start-up current value (100A), the current limiting function will be turned on; the current limiting operation will be turned off 2 minutes later; and whether the charging current is more than the start-up current value will be detected. If it is the case, start current limiting operation again. After 5 times of such detections, the current limiting state will be locked as 10A until the lock is removed after the overvoltage protection disconnects MOS or the discharging current is above 1A.

7. BMS (Battery Management System) Function

7.2 Communication Interfaces of BMS

■ CAN and RS485 Interfaces

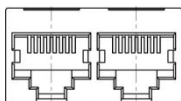

The 8P8C Vertical-type RJ45 Socket is applied for RS485		The 8P8C Vertical-type RJ45 Socket is applied for CAN	
RJ45 Pin	Definition Description	RJ45 Pin	Definition Description
1 and 8	RS485-B1	9, 10, 11, 14 and 16	NC
2 and 7	RS485-A1	12	CANL
3 and 6	GND	13	CANH
4 and 5	NC	15	GND

Remarks: The default CAN communication rate is 500K.

■ RS485 Parallel Interface

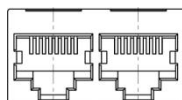

The 8P8C Vertical-type RJ45 Socket is applied for RS485		The 8P8C Vertical-type RJ45 socket is applied for RS485	
RJ45 Pin	Definition Description	RJ45 Pin	Definition Description
1 and 8	RS485-B	9 and 16	RS485-B
2 and 7	RS485-A	10 and 15	RS485-A
3 and 6	GND	11 and 14	GND
4 and 5	NC	12 and 13	NC

Pack information can be viewed with double RS485 interfaces. The default Baud rate is 9,600bps. If it is required to communicate with the monitoring device through RS485, the monitoring device should be used as the host machine. The address setting range is 2 ~ 15 based on the address polling data.

7. BMS (Battery Management System) Function

■ Communication Interfaces

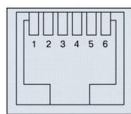

The 6P6C Vertical-type RJ11 Socket is applied for RS232	
RJ45 Pin	Definition Description
2	NC
3	TX (single plate)
4	RX (single plate)
5	GND

8. Product Commissioning

8.1 Commissioning Preparations

- Ensure that all the devices can be used for operation, maintenance, and repairs before powering them on.
- Check and make sure the battery cabinets have securely and smoothly installed.
- Ensure that there are no sundries piled up on the top of the product.
- The wiring harness interfaced between the battery cabinets or between the battery cabinet and the wiring harness interface of the external system should properly be connected.
- Cables should be arranged in a secure place or any mechanical damage should be prevented.

8.2 Commissioning of Functions

If all the above items meet relevant requirements, start the product for the first time according to the methods specified in “General Operation” in Chapter 6.

If you have any other problems during debugging, please contact Contemporary Nebula.

9. Fault and Maintenance

9. Fault and Maintenance

If you encounter the following problems during use of the product, please refer to the relevant solutions listed below. If your problem still exists, please consult Contemporary Nebula.

General Faults and Solutions

Serial No.	Fault Phenomenon	Analysis of Causes	Solutions
1	No DC output after startup	Over-discharge protection due to low battery voltage	Carry out charging
2	No working of the indicating lamp after startup	BMS is in the dormant state	Restart the Reset Switch
3	Indicating insufficient electric quantity	Too low charging voltage	Adjust the floating charge voltage of the switching power supply to the required parameters
4	Short power supply time	The battery pack is not full charged	Check the charging voltage, current and other parameters of the switching power supply
5	Unstable output voltage after startup	BMS is interrupted	Restart the Reset Switch
6	Communication failure	Problems in communication line	Check the address setting of the address switch, ports and lines
7	The positive and negative connectors are overheating	The electrical connection is not in position	Re-operate the electrical connection part in accordance with the installation steps

Regular Maintenance

- (1) According to the power-down steps, power down the battery;
- (2) Inspect the output terminal screws for any looseness; Check that the plug and socket connectors are properly and securely connected;
- (3) Measure the output voltage to see whether it is within the normal range;

9. Fault and Maintenance

- (4) Check with the software of the upper computer to see whether the communication interface works normally;
- (5) Check with software of the upper computer to see whether the voltage, current, electricity quantity, and temperature of single cell in the battery pack is detected accurately.

10. Specification Table of the Product

10. Specification Table of the Product

Battery Model	BB-LFP-100Ah-P/Lithium Iron Phosphate (LFP) Battery
Running voltage	44.8~57.6 (rated voltage: 51.2V)
Battery specification	LFP3.2V/100Ah
Nominal capacity at 25°C	5.12kWh
Depth of discharge	95%
Number of cycles	>6000 @ 70%SOH
Charging working temperature	5°C~55°C
Discharging working temperature	-20°C~55°C
Standard charging process	Charge at 0.5C at the ambient temperature of 25°C±2°C, and stop charging when the unit voltage reaches 3.6V.
Standard discharging process	Discharge at 0.5C at ambient temperature of 25°C ±2°C, and stop discharging when the unit voltage reaches 2.8V.
Storage temperature range	-20°C~60°C (50% SOC and 0~25°C recommended for long-term storage)
Cooling mode	Natural heat dissipation
Recommended temperature of service environment	-20°C-25°C for indoor or waterproof areas
Shipping capacity	50% SOC
Communication mode	CAN/RS485 (either of the two) for external communication and RS485 for communication between modules
Environment humidity	0-95%, no condensed water, unavailable in salt spray area or near coastal environment
Working altitude	≤2000m

11. Diagram of the battery system

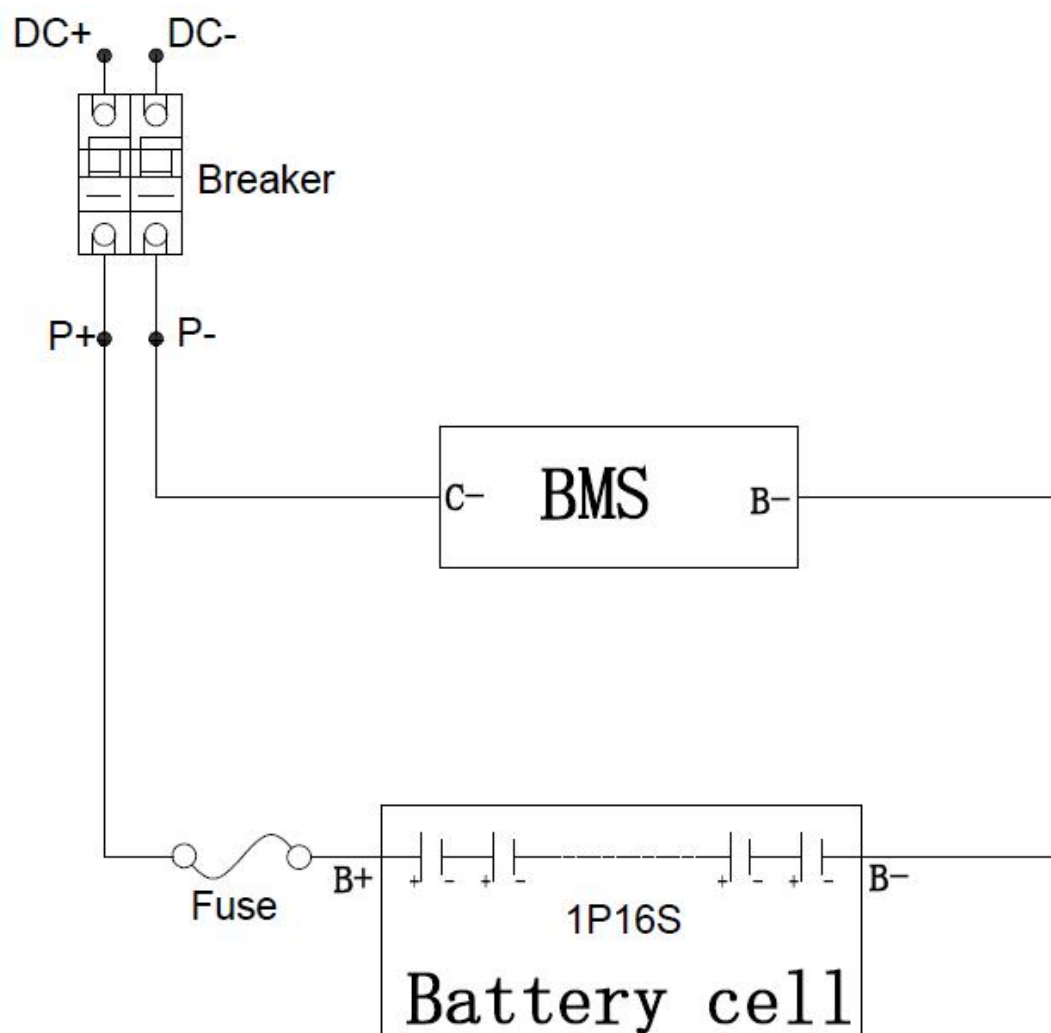

12. Transportation

12.1 Transportation

The system is installed in the fixed manner, moving mode of which mainly depends on the mechanical forklift to assist the movement. Attention should be paid to the center of gravity of the system and the position of the cabinet pushed by hand during transportation. Attention should also be paid to the flatness of the ground during transportation. When transported to places with uneven ground, relevant measures should be taken to prevent severe bumping of the cabinet. As for long-distance transportation, the vehicle meeting the requirements for the transportation of electronic products should be selected.



Warning!

When moving the products of this system, please use forklifts meeting the rated lifting capacity and the forklift with the appropriate fork-entry span. Be sure to fork the cabinet from the bottom. The cabinet shall be supported from four sides when lifted with fork; and precautions shall be taken to prevent the cabinet from tilting during transportation.

Please move the product with the power or manual forklift.



12.2 Inspections after Arrival of the Product

First, remove the outer packaging of the system after arrival of the product. Secondly, check to see whether the attached parts are complete, and whether the accessories are missing according to the packing list. Last, check to see whether there is significant defect on the shell of the system.

If the accessories are not complete or there are significant defects on the shell, please contact the Company according to the contact information on the cover.

13. After-sales Service

Warranty Card

Customer Information	
* Name of User _____	* Phone Number _____
* E-mail _____	Company Name _____
*Address _____	
*Status _____	Postal Code _____
Product Information	
* Module Type _____	
* Product Number _____	
* Date of Purchase _____	
* Fault Description _____	
1) Can the battery be turned on?	Yes or No?
2) Can the battery be charged?	Yes or No?
3) Can the battery be discharged?	Yes or No?
4) Is the red lamp on?	Yes or No?
5) Is the lamp on?	Yes or No?
Information on Installation Procedure	
* Name of Installation Procedure _____	
Number of Personnel _____	
* Date of Installation _____	
Please fill in the information carefully. The items marked with "*" are required items. Thank you!	
* Signature of Customer _____	
* Signature of Supplier _____	
* Date _____	
Mailing Address: No. 26-1, Majiang Road, Mawei Town, Mawei District, Fujian Province	
Service Hotline: 86-0591-83970008	
Service E-mail: cnte.shfw@cntepower.com	
Note: Please keep this Card properly. In case of repair, please contact Time Nebula Maintenance Center for repair with this Card and the official purchase invoice.	

Warranty Regulations

Warranty Regulations

The warranty period of the battery cabinets for residential energy storage purchased by users shall be calculated from the date of the completion of commissioning and installation or six months after the date of manufacturing. If the certificate of “three guarantees” (for repair, replacement or compensation of the faulty product) and the valid invoice cannot be provided, date of purchase shall be calculated according to date of ex-works which the barcode corresponde to. However, the following conditions are not covered by the warranty:

1. Products that are installed, maintained, or operated not in accordance with User's Manual;
2. Products that are in moving or shaking condition after installation; or the temperature of the products is above 45°C or below -20°C;
3. The original buyer fails to inform CNTE of the defect or degradation within 30 days after discovering the defect or degradation;
4. Products that are not installed within a month since the warranty date;
5. Use of the non-CNTE adaptive inverter indicated in the CNTE standard configuration list to run the product;
6. Modification or maintenance of the product without approval of CNTE;
7. Force majeure events (Flood, fire, earthquake, lightning and other natural disasters or other abnormal environment, wars and other events);
8. Significant damages to the products during transportation;
9. Changes in national or regional laws, regulations or instructions;
10. Products that are not in operation for any period of no less than 6 months.

Note:When users purchase this product due to normal use or other abnormal faults,they shall notify the company,the company or the company’s recognized recycling service providers to recycle waste batteries.

Warning

Warning

Dear _____ (Sir/Company),

Thank you for purchasing and using our product!

Since the product you purchased is a technical product, you need to strictly follow the operation instructions in User's Manual. Be sure to read and understand the instructions carefully before using the product.

If the operation instructions shown in the Manual are violated, the product may be damaged, or out of control. Besides, smoking, firing and other serious consequences may be caused.

Thank you for your understanding!

Contemporary Nebula Technology Energy Co., Ltd.

Date: _____



Contemporary Nebula Technology Energy Co., Ltd.

Address: No. 26-1, Majiang Road, Mawei Town, Mawei District, Fujian Province

E-mail: cntepower@cntepower.com

Phone: +86-0591-83970038

Website: www.cntepower.com